

Section A

Answer **all** questions in this section.

A1 A photo mount for a picture frame is shown below.

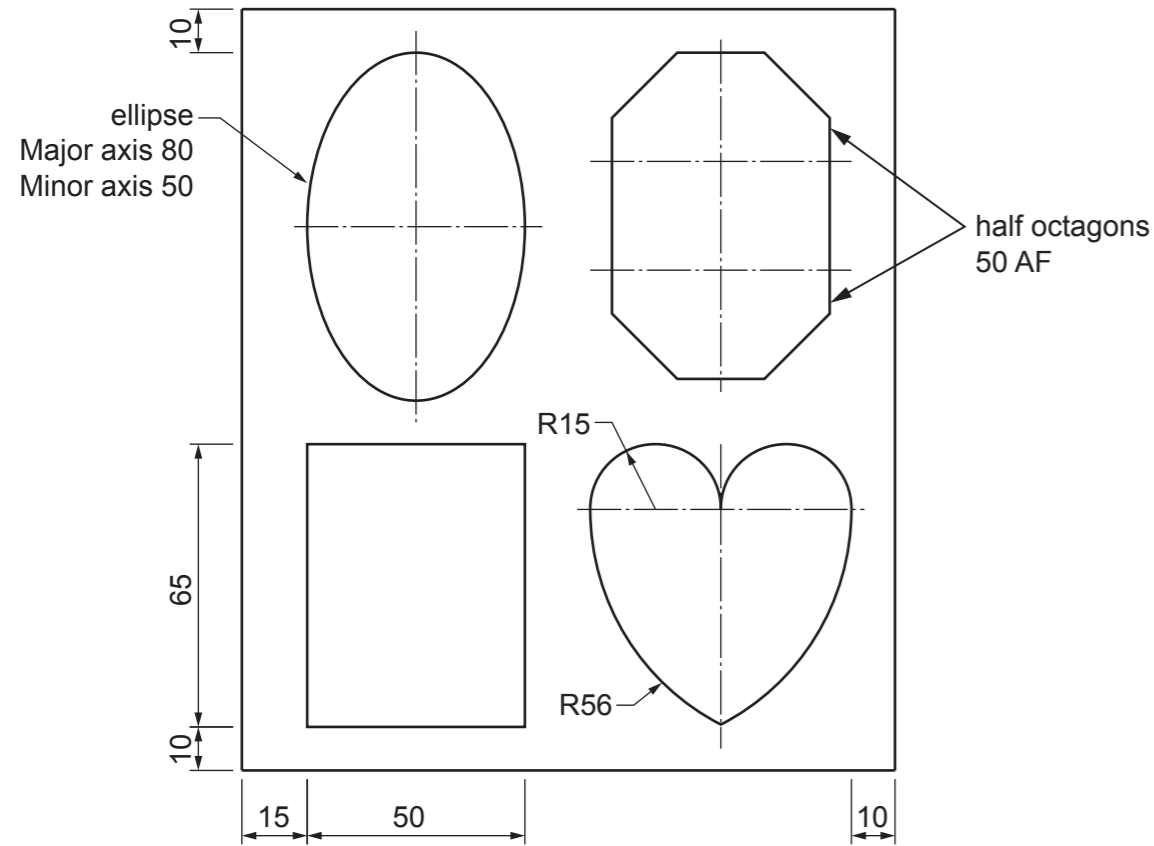

In the space provided to the right, complete the full size drawing of the photo mount by constructing:

- (a) the rectangle shape [2]
- (b) the ellipse shape [6]
- (c) the eight sided shape [4]
- (d) the heart shape. [4]

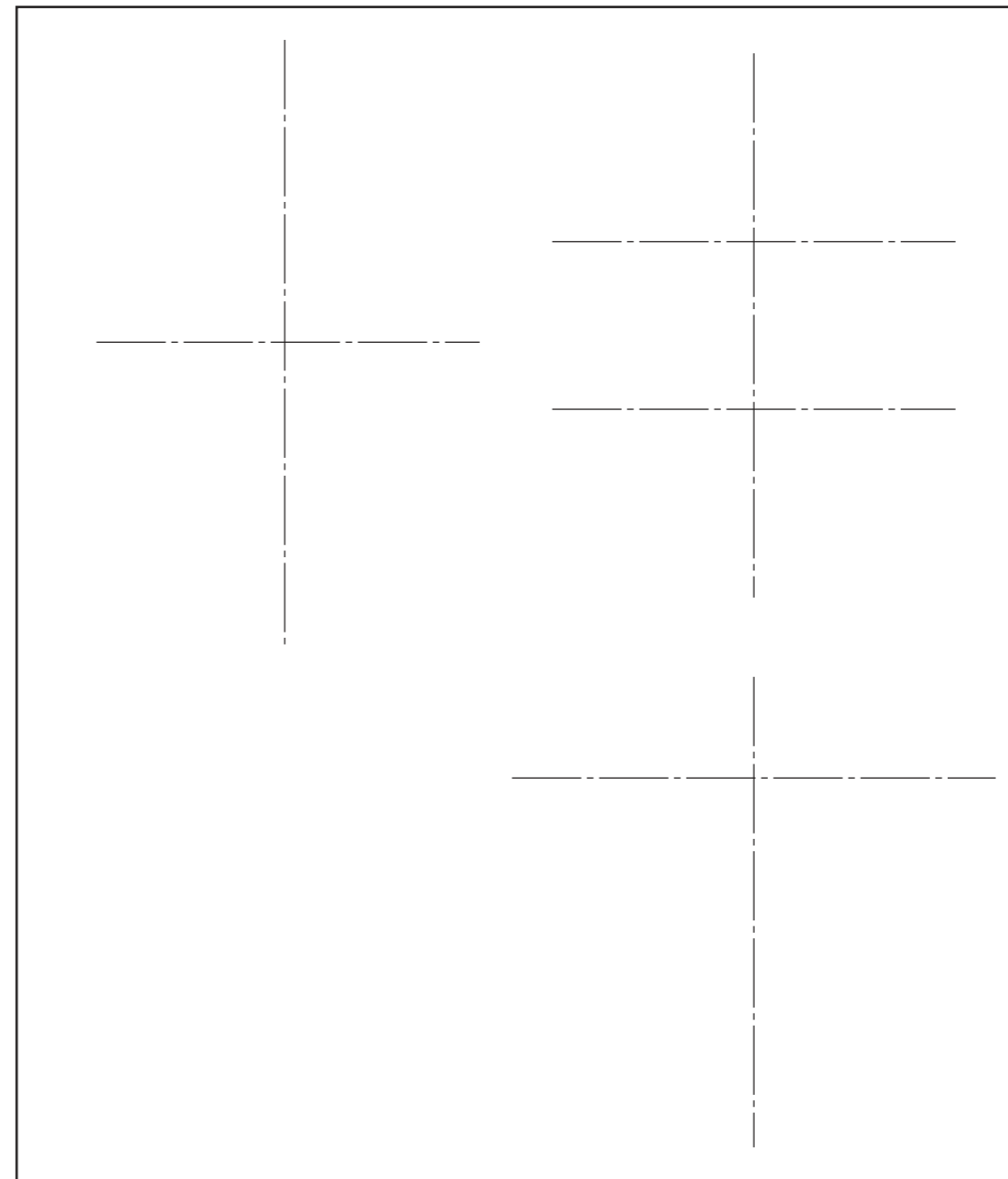

full size drawing of the photo mount

A2 The photo mount is made from thin card.

The shapes will be cut out by hand using a craft knife.
Name **one** other item of equipment you would need to use when cutting out the shapes with a craft knife.

..... [1]

For
Examiner's
use

0445/53 Oct/Nov 2020 **1 hour**
© UCLES 2020 DC (LK/SW) 186129/3

Centre Number Candidate Number Candidate Surname Other Names **[Turn over**

A3 Parts for a picture frame are shown below.

A sectional view through the frame is also shown.

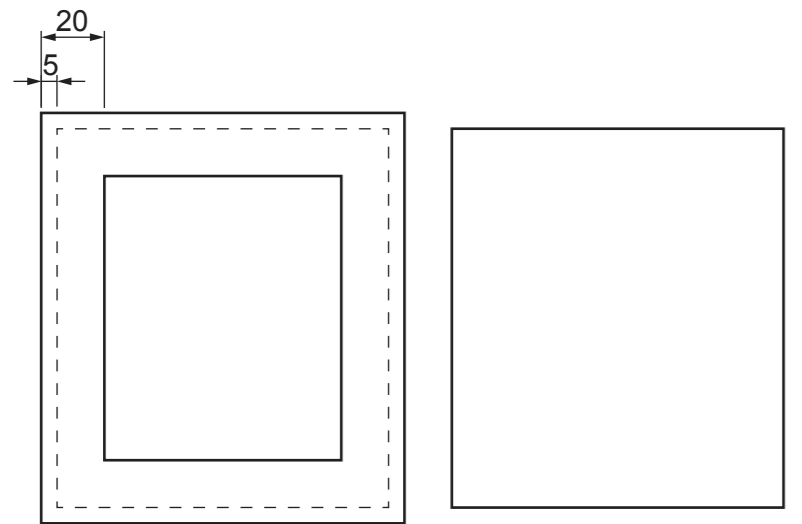

frame 160 × 130

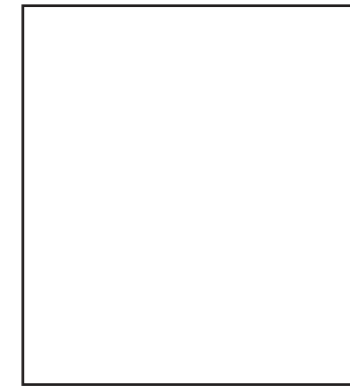

6 mm thick glass 150 × 120

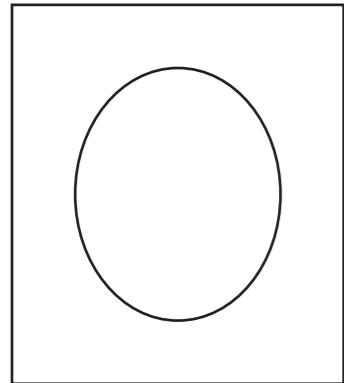

2 mm thick photo mount
150 × 120



8 mm thick backboard
150 × 120

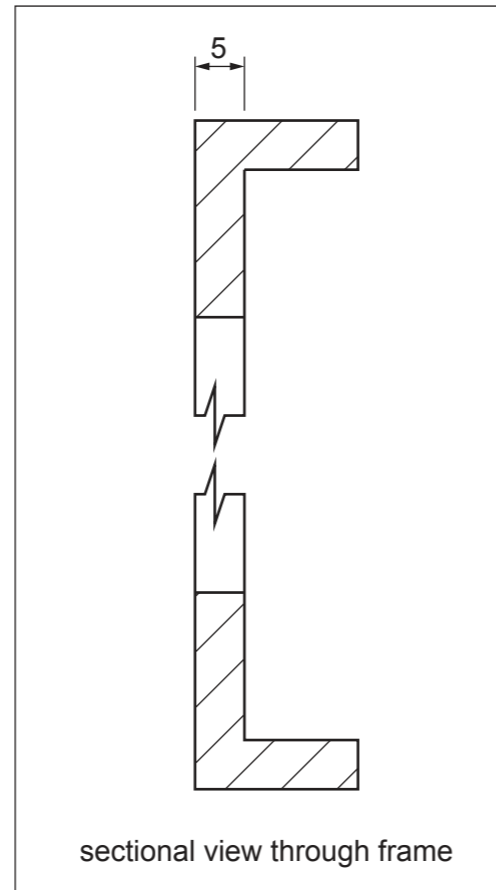

sectional view through frame

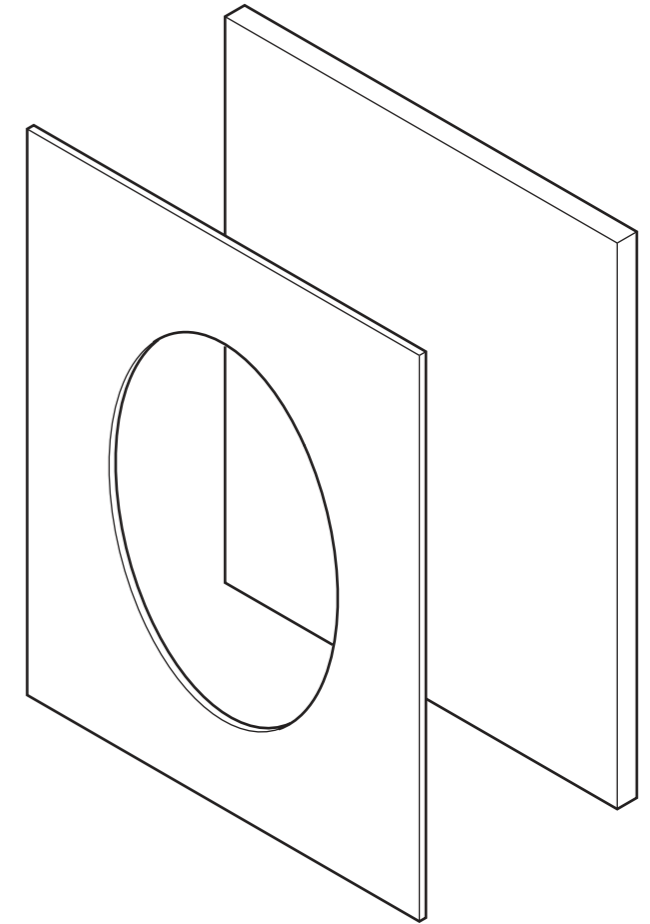
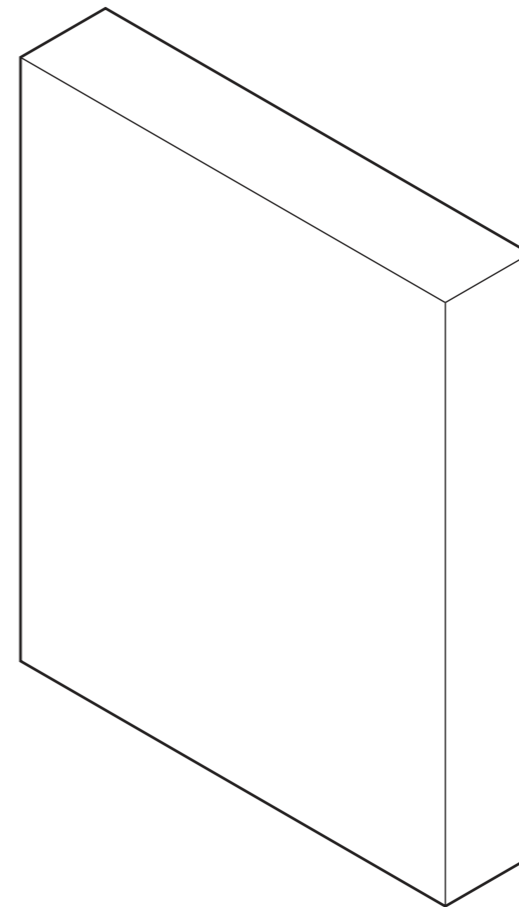

Complete the half scale exploded isometric view of the picture frame by adding:

- (a) the glass between the mount and the frame [4]
- (b) the rectangular hole in the frame. [4]

Section B
Answer **either** question **B4** or **B5**.

B4 A photo holder is shown below.

- (a) Apply thick and thin line technique to the photo holder. [6]

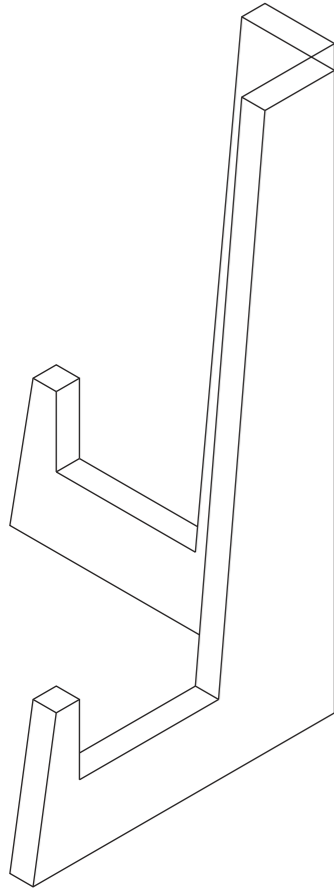

(b) Isometric views of another photo holder are shown below. Complete the full size orthographic views of the photo holder by adding:

- (i) the side view including hidden detail [6]
(ii) the plan view. [7]

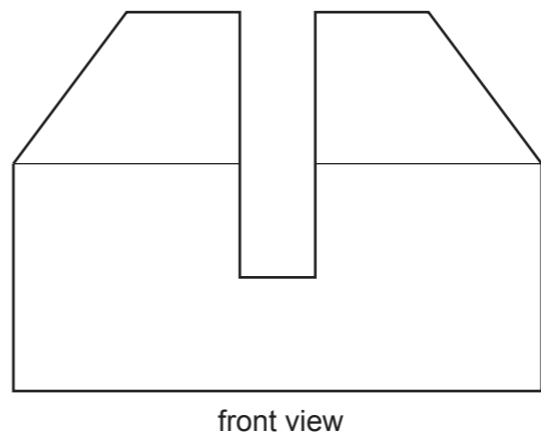
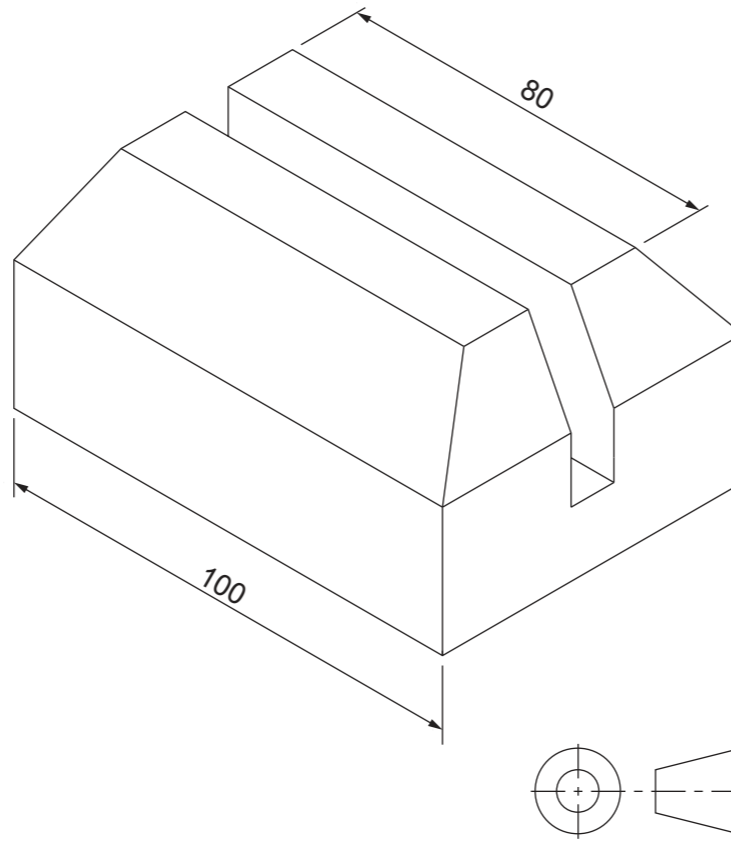

plan

front view

side view

(c) A cardboard photo holder is shown below. In use, the rear support folds in too easily.

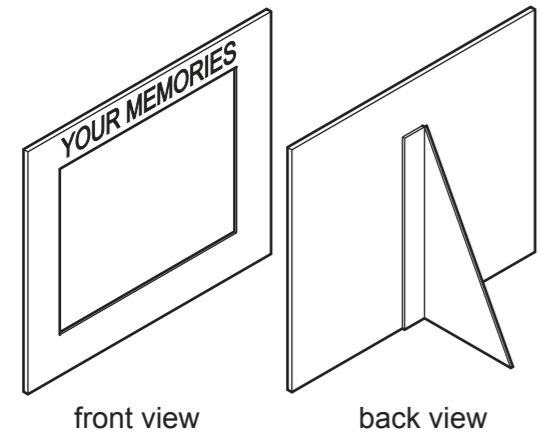

Use sketches and notes to show an alternative design for the rear support that will hold the photo in an upright position on a desk, but fold flat when not in use. [3]

(d) The photo holder in **part (c)** will be produced in quantities of 10 000.

- (i) State a suitable method of printing the lettering onto the cardboard photo holders. [1]

- (ii) Explain one reason why some types of printing are only cost effective in large quantities.

..... [2]

For Examiner's use

B5 A package for a photo frame is shown below.

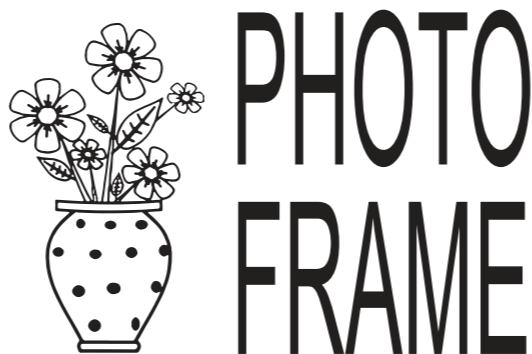
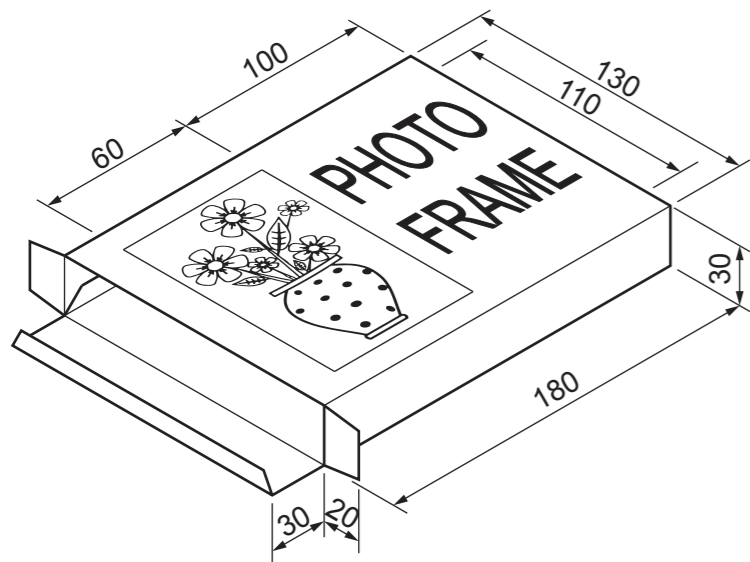

(a) (i) In the space provided, complete the half size development (net) of the photo frame package. [14]

(ii) Add the rectangle around the image. [2]



(b) The image on the front of the photo frame package is shown on the right.

The image is drawn on paper by hand before being transferred onto a computer.

(i) State **one** method of transferring the image from paper onto the computer. [1]

.....

(ii) Name **two** ways the image could be altered using a computer. [2]

1

2

(iii) Name **one** suitable piece of CAM equipment that could be used to cut out the development (net) of the package from thin card. [1]

.....



(c) An alternative package for the photo frame is shown below.

The plastic blister of the package is made using a vacuum former.

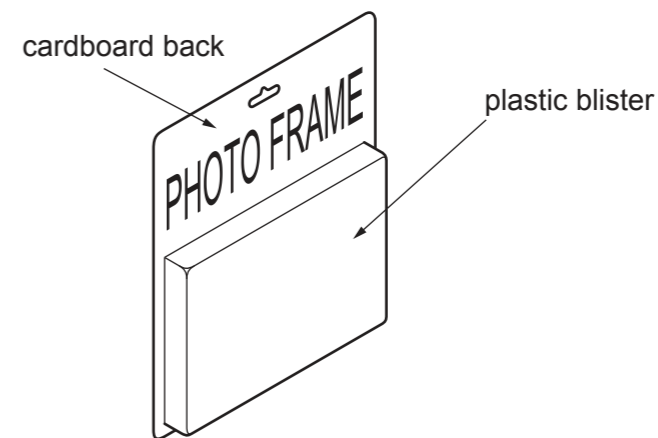

(i) In the space below complete the flow chart of the vacuum forming process.

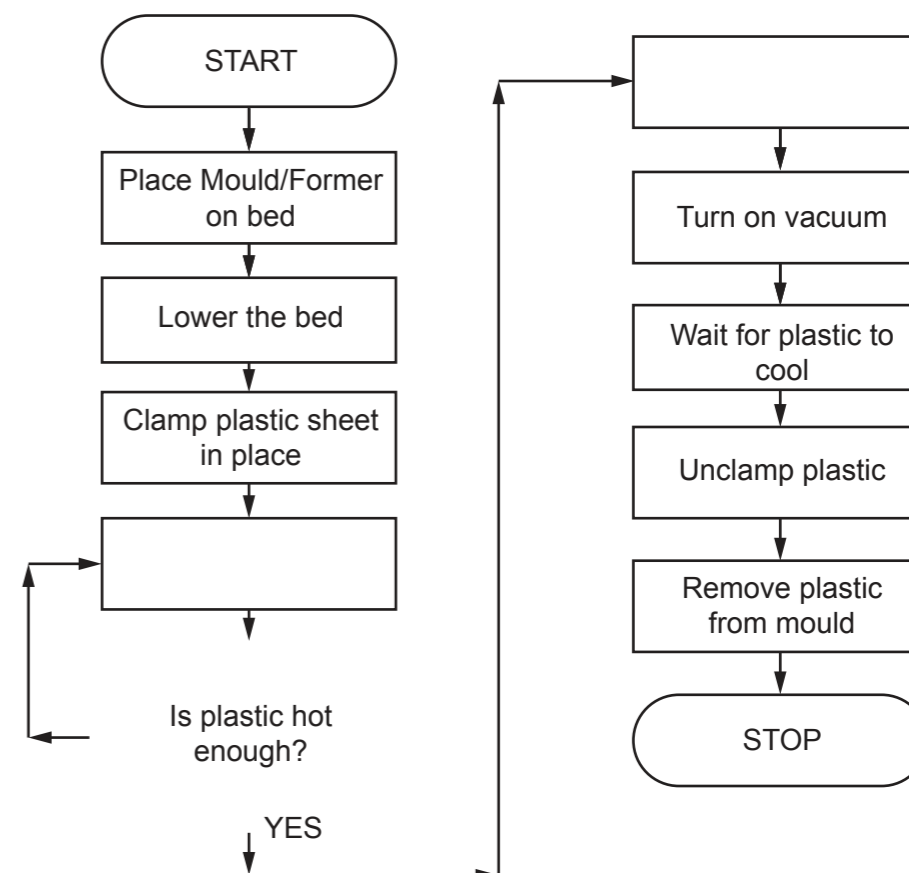

(ii) A side view of the mould for the vacuum formed blister is shown below.

Sketch a modification onto the side view of the mould that will allow the plastic blister to be removed more easily.

